

1 | 2 | 3 | 4 | 5 | 6 | 7 | 8

A

B

C

D

E

BILL OF MATERIALS				
NO.	DESIGNATION	QTY	MATERIAL	NOTES
1	BODY	1	ASTM A216 WCB	
2	VALVE NUT	1	ASTM A194 2HM	
3	DISC NUT PIN	1	CARBON STEEL	
4	DISC WASHER	1	CARBON STEEL	
5	HINGE	1	ASTM A216 WCB	
6	DISC	1	ASTM A216 WCB+STL	
7	SEAT	1	ASTM A105+13%Cr	
8	HINGE PIN	1	ASTM A182 F6a	
9	BEARING BRACKET	1	ASTM A216 WCB	
10	BEARING BRACKET BOLT	1	ASTM A193 B7M	
11	SPRING WASHER	1	SPRING STEEL	
12	BONNET	1	ASTM A216 WCB	
13	GASKET	1	304+GRAPHITE	
14	SEPARATE RING	1	ASTM A276 410	
15	COVER	1	ASTM A216 WCB	
16	COVER BOLT		ASTM A193 B7M	
17	COVER NUT		ASTM A194 2HM	
18	STATIONARY RINGS	1	CARBON STEEL	
19	THRUST RING	1	ASTM A276 410	

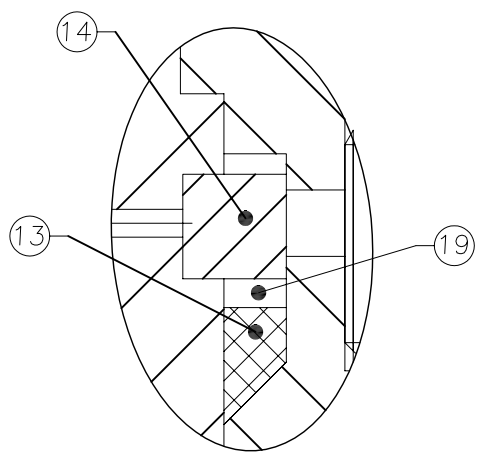

Detail B

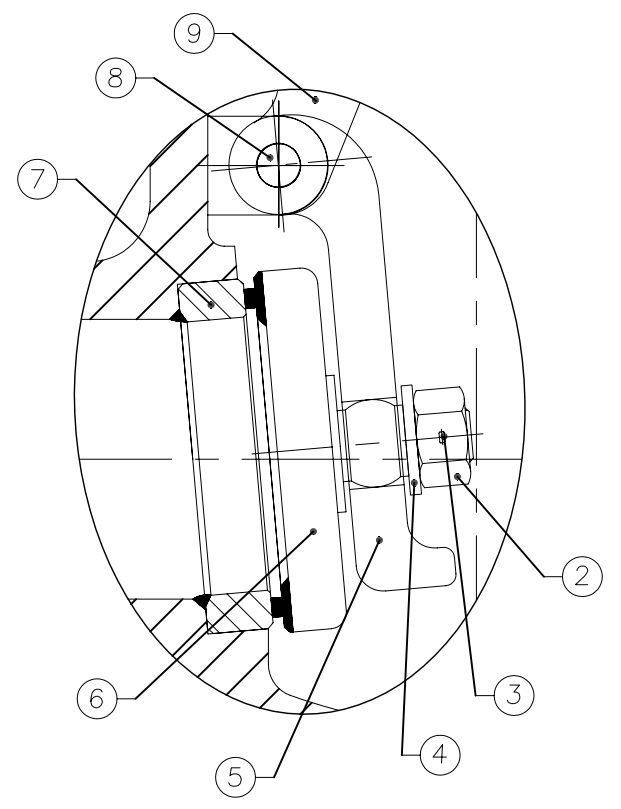

Detail A

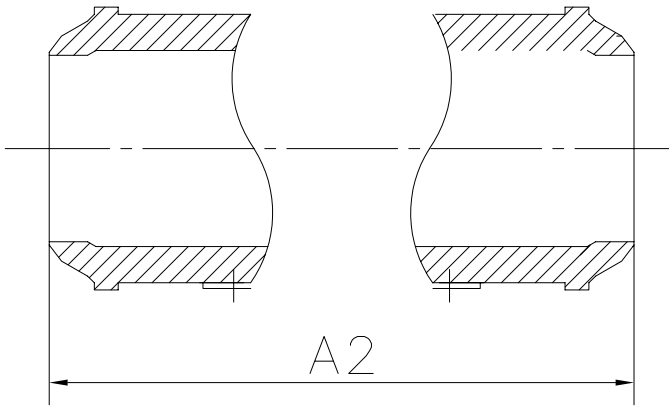
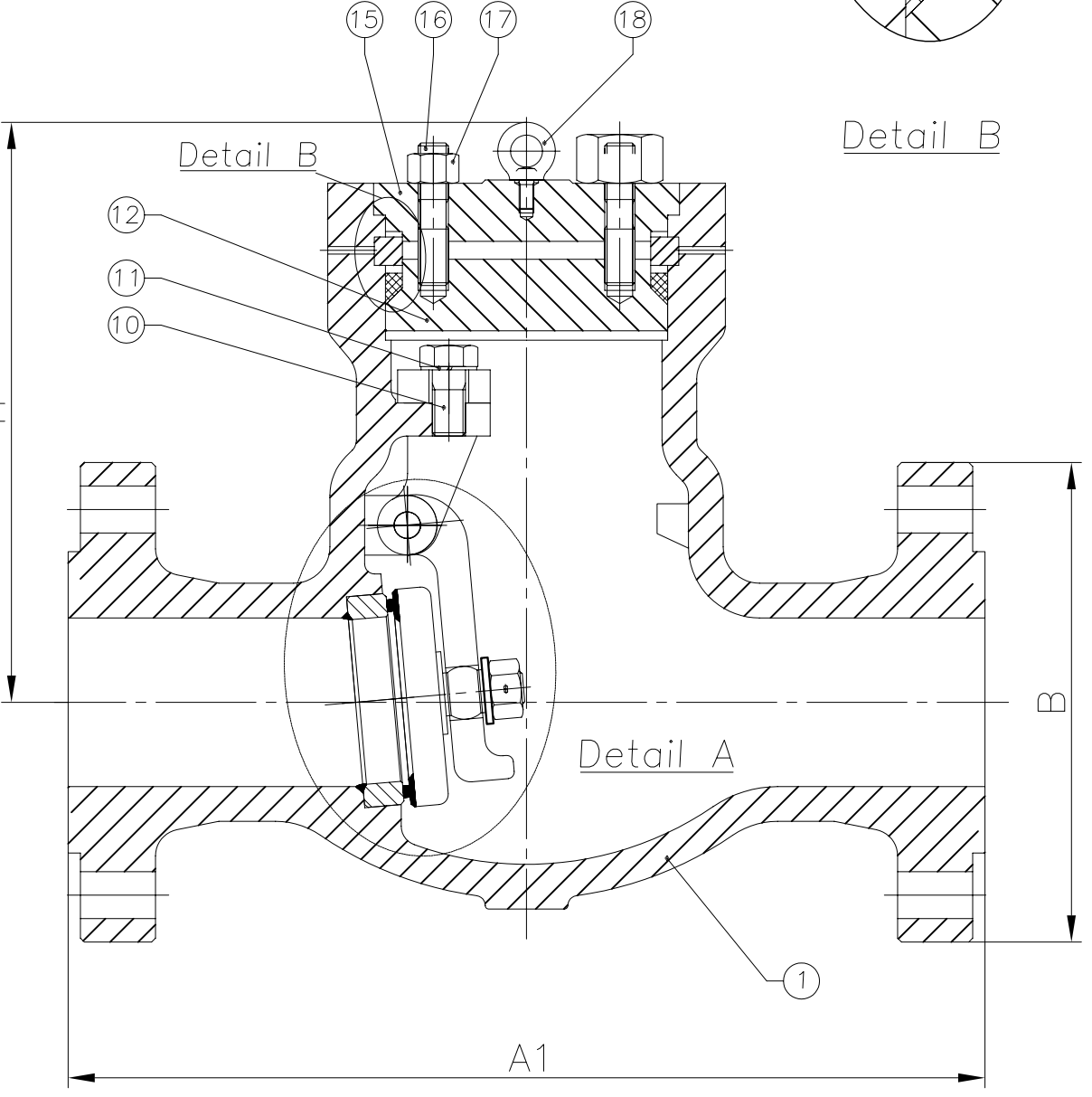

Butt-Weld Ends

Size	A1	A2	B	H
2	451	279	235	245
3	578	368	305	270
4	673	457	356	318
6	914	610	483	451
8	1022	762	550	559
10	1270	914	675	578
12	1422	1041	760	654

ENGINEERING DATA

DESIGN CODE	BS 1868/ANSI B16.34	TEST PRESSURES		
FACE TO FACE DIMENSIONS	ASME B16.10	BODY	638.25	Barg
ENDS CONNECTION DIMENSIONS	ASME B16.25	SEAT	468.05	Barg
TESTING CODE	API 598	BACKSEAT	468.05	Barg
		AIR - SEAT	6.0	Barg

BY	CHK	APP	SCALE:	
			DRAWN	DATE
			CHECKED	DATE
			APPROVED	DATE

DRAWING TITLE:
 API CAST STEEL CLASS 2500
 PS BONNET, RF, SWING CHECK VALVE
 PROJECT:
 PACKAGE:
 VENDOR DOC.NO.:



CAD. No.	DRAWING NUMBER:	120056	REV
	AREA No.	FACILITY	TYPE
	SEQ. No.	SHT. No.	

1 | 2 | 3 | 4 | 5 | 6 | 7 | 8